

DESIGN NOTES

Hot Swapping the CompactPCI Bus – Design Note 200

Robert Reay

One of the reasons for the increase in popularity of the CompactPCI™ bus is its ability to be hot swapped into and out of a live backplane without turning off the system power. One of the key elements required for hot swapping a CompactPCI board is the power supply isolation controller.

The LTC®1643L is designed to meet the power supply isolation requirements found in the CompactPCI Hot Swap™ Specification PICMG™ 2.1. The chip will turn a board's supply voltages on and off in a controlled manner, allowing the board to be safely inserted or removed without causing glitches on the power supplies and causing other boards in the system to reset. It also protects against short circuits and reports the state of the supply voltages via the HEALTHY# signal.

LTC1643 Feature Summary

The LTC1643 features can be summarized as follows:

1. Controls all four CompactPCI supplies: -12V, 12V, 3.3V and 5V.
2. Programmable foldback current limit: a programmable analog current limit with a value that depends on the output voltage. If the output is shorted to ground, the current limit drops to keep power dissipation and supply glitches to a minimum.

LTC and LT are registered trademarks of Linear Technology Corporation. Hot Swap is a trademark of Linear Technology Corporation. CompactPCI and PICMG are trademarks of the PCI Industrial Computer Manufacturers Group.

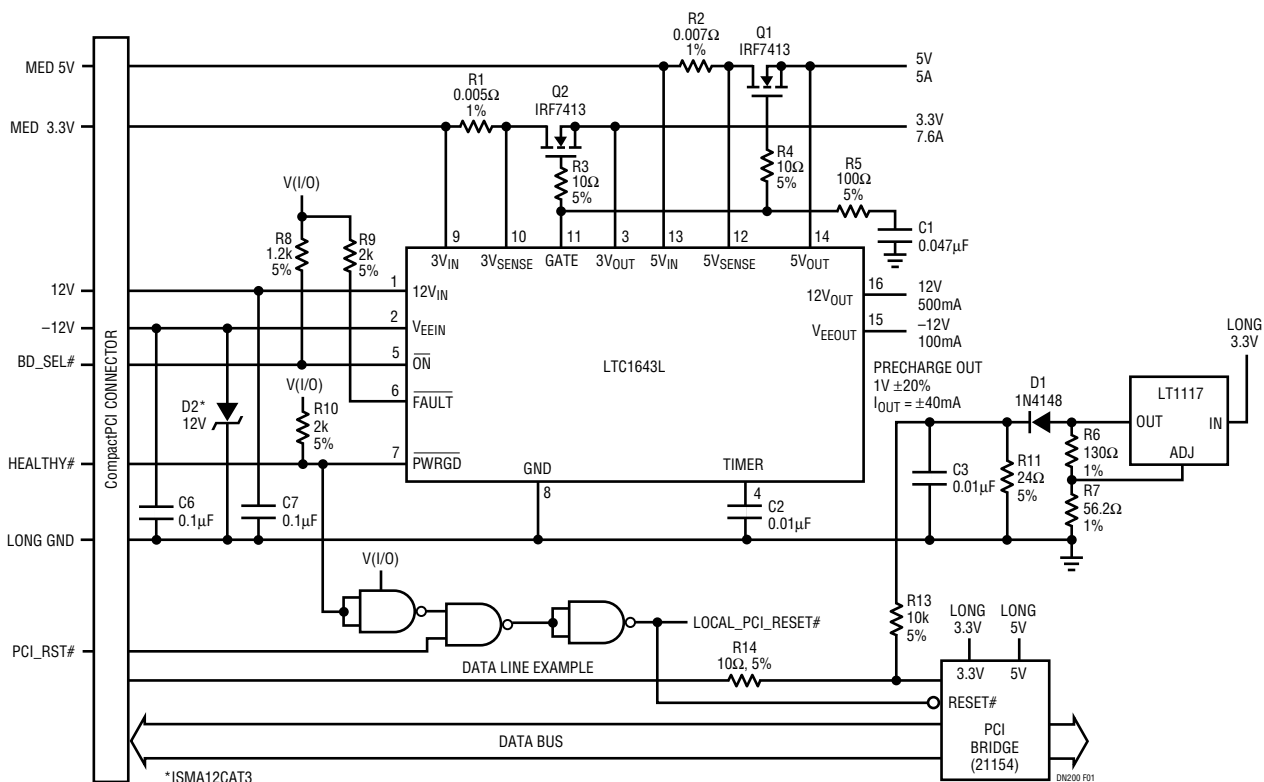

Figure 1. Typical CompactPCI Application

3. Programmable circuit breaker: if a supply remains in current limit too long, the circuit breaker will trip, the supplies will be turned off and the FAULT# pin will be pulled low.
4. Current limited power-up: the supplies are allowed to power up in current limit. This allows the chip to power up boards with large capacitive loads without tripping the circuit breaker. The maximum power-up time is programmable using the TIMER pin.
5. -12V and 12V power switches on chip.
6. BD_SEL# and HEALTHY# signals.
7. Space-saving 16-pin SSOP package.

Typical Application

Figure 1 shows a typical application using the LTC1643L.

The power supplies are controlled by placing external N-channel pass transistors Q1 and Q2 in the 5V and 3.3V power paths. Internal pass transistors control the 12V and -12V power paths. Resistors R1 and R2 sense overcurrent conditions and R5 and C1 provide current control loop compensation. Resistors R3 and R4 prevent high frequency oscillations in Q1 and Q2. Capacitor C2 provides the power-up timing and C6 and C7 provide chip bypassing on the 12V and -12V inputs. Diode D2 protects the part from voltage surges below -15V on the -12V supply.

The 3.3V, 5V, 12V and -12V inputs of the LTC1643 come from the medium length power pins on the CompactPCI connector. The long 3.3V, 5V and V(I/O) pins power up the bus-precharge circuit, the PCI bridge chip and the LOCAL_PCI_RESET# logic. The BD_SEL# signal is connected to the ON pin and the HEALTHY# signal is connected to the PWRGD pin. The HEALTHY# signal is combined with the PCI_RESET# signal to generate the LOCAL_PCI_RESET# signal.

The 1V precharge voltage for the data bus lines is generated by an LT[®]1117 low dropout regulator. The output of the LT1117 is set to 1.8V, then the voltage is dropped by an 1N4148 diode to generate 1.0V. The precharge circuit is capable of sourcing and sinking 40mA.

Power-Up Sequence

Figure 2 shows a typical power-up sequence.

When the BD_SEL# is pulled low, the pass transistors are allowed to turn on and a 20 μ A current source is connected to the TIMER pin. The current in each pass transistor increases until it reaches the current limit for that supply. Each supply is then allowed to power up at the rate

$dv/dt = 50\mu A/C1$ or as determined by the current limit and the load capacitance, whichever is slower. Current-limit faults are ignored while the TIMER pin voltage is ramping up. Once all four supply voltages are within tolerance, the HEALTHY# signal will pull low.

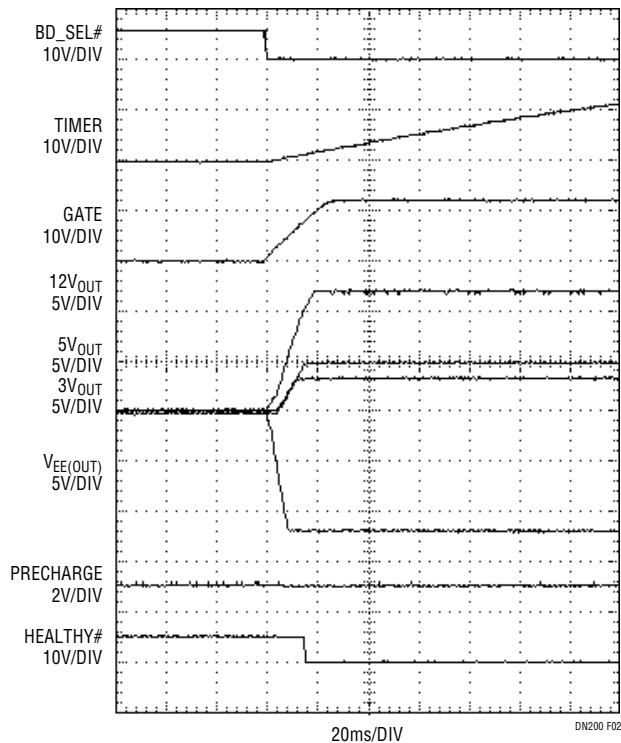

Figure 2. Normal Power-Up

Conclusion

Using the LTC1643L, a CompactPCI board can be made hot swappable so the system power can remain on when the board is inserted or removed. With the LTC1643L, safe hot-swapping becomes as easy as hooking up an IC, a couple of power FETs and a handful of resistors and capacitors.

Hot Swap Net Seminar
 Thursday, April 8th, 1999, 9am & 7pm PDT
 Register at www.linear-tech.com/go/hotswap

Win a FREE Palm Pilot!

For literature on our Hot Swap Controllers, call **1-800-4-LINEAR**. For applications help, call (408) 432-1900, Ext. 2361